

USER MANUAL

L-Series Switchgear



RIGHT FROM
THE START

AuCom
MOTOR CONTROL SPECIALISTS

Contents

Section 1	Caution Statements	2
Section 2	About This Manual	3
2.1	Purpose and target audience.....	3
2.2	Reference documents.....	3
Section 3	General Description	4
3.1	Overview.....	4
3.2	Feature List	4
3.3	Resistance to Internal Arc Faults	4
3.4	Safety Features	4
3.5	General Technical Data.....	6
Section 4	Panel Specifications	7
4.2	Panel Arrangement.....	7
4.3	Soft Starter Panel (SSP).....	9
4.4	Standard Panels	10
Section 5	Receiving and Storage	12
5.1	Receiving.....	12
5.2	Storage.....	12
Section 6	Installation	13
6.2	Clearance Requirements	15
6.3	Lifting and Moving	16
6.4	Busbar Installation	17
6.5	Earth Termination.....	18
6.6	Assembling the Switchgear Line-up.....	18
Section 7	Operation and Maintenance	20
7.1	Earth Switch Operation.....	20
7.2	Main Switching Apparatus Operation.....	21
7.3	Access to Compartments	21
7.4	Maintenance.....	22
Section 8	Appendix	23
8.1	Bolting Torques.....	23

Section I Caution Statements



This symbol is used throughout this manual to draw attention to topics of special importance to the installation and operation of L-Series switchgear panels.

Caution Statements cannot cover every potential cause of equipment damage but can highlight common causes of damage. It is the installer's responsibility to read and understand all instructions in this manual prior to installing, operating or maintaining the soft starter, to follow good electrical practice including applying appropriate personal protective equipment and to seek advice before operating this equipment in a manner other than as described in this manual.



WARNING - ELECTRICAL SHOCK HAZARD

Medium voltage equipment contains dangerous voltages when connected to mains voltage. Only a competent trained person should carry out the electrical installation. Improper installation of the motor or the soft starter may cause equipment failure, serious injury or death. Follow this manual and local electrical safety codes.



ELECTROSTATIC DISCHARGE (ESD)

Many electronic components are sensitive to static electricity. Voltages so low that they cannot be felt, seen or heard, can reduce the life, affect performance, or completely destroy sensitive electronic components. When performing service, proper ESD equipment should be used to prevent possible damage from occurring.



ARC FLASH HAZARD

Medium voltage equipment has a potential risk of arc flash. When insulation or isolation between electrified conductors is breached or can no longer withstand the applied voltage, a short circuit occurs through the air. This may cause a phase-to-ground and/or a phase-to-phase fault.

AuCom medium voltage equipment has been designed to mitigate an arc fault, however it is the responsibility of the site engineer to ensure that personnel are protected from serious injury that may result from an arc fault.

Although unlikely, arc fault can be caused by:

- Contamination in the insulation caused by deterioration over time
- Inadequate insulation system on cable terminals
- Overvoltage
- Incorrect protection coordination settings
- Overheating of the contact area, due to incorrect tightening of connections
- Introduction of foreign matter, including swarf, vermin, tools or maintenance equipment left in the starter

© 2022 AuCom Electronics Ltd. All Rights Reserved.

As AuCom is continuously improving its products it reserves the right to modify or change the specification of its products at any time without notice. The text, diagrams, images and any other literary or artistic works appearing in this document are protected by copyright. Users may copy some of the material for their personal reference but may not copy or use material for any other purpose without the prior consent of AuCom Electronics Ltd. AuCom endeavours to ensure that the information contained in this document including images is correct but does not accept any liability for error, omission or differences with the finished product.

Section 2 About This Manual

2.1 Purpose and target audience

This manual is meant to assist qualified personnel in the installation, operation and maintenance of L-Series switchgear panels. Read this manual carefully before installing switchgear panels within the operating environment.

This manual must be readily accessible to all persons operating the switchgear as well as installation technicians responsible for commissioning the product.

The information contained in this manual is indicated for typical switchgear configurations only. Please refer to the drawings and supplementary documentation provided by AuCom for detailed technical data. In case of a conflict between this document and any supplementary documentation provided by AuCom, the latter will always take precedence.

2.2 Reference documents

The following additional documents are required:

- MVX IP00 user manual.
- Installation and operating instructions for devices installed in switchgear panels:
 - Switching apparatus (eg circuit breaker, contactor).
 - Devices in the low voltage section.
- Assembly instructions for the cable connection systems which will be connected to the switchgear (supplied by the cable system manufacturer).
- Drawings and supplementary documentation provided by AuCom.

**NOTE**

This manual cannot describe every configuration or customisation of the L-Series switchgear panel. For information which is not included in this manual, please contact AuCom.

Section 3 General Description

3.1 Overview

L-Series panels provide isolation and electrical switching for the soft starter and its associated switchgear. Each panel is divided into a number of compartments which house switchgear components and physically isolate one from the other.

The panel has been designed to be arc-fault resistant. Door interlocks prevent accidental access to panel compartments during operation.

3.2 Feature List

Design

- Pressure resistant viewing windows to inspect switchgear without opening doors
- Front doors and a removable rear panel to access compartments and cabling
- Lifting lugs allow easy lifting and relocation of entire unit
- Transition panels for placement and interconnection between panels
- Panels are compartmentalised for isolation between electrical sections (medium and low voltage)

Safety

- Fully type tested including internal arc tests according to IEC 62271-200 (IAC classified: AFLR, 31.5kA/1s).
- Mechanical interlocks prevent access to electrical sections during operation
- All switching operations can be performed with the doors closed
- Front doors and side panels powder coated (RAL7035)

Ventilation and Temperature Management

- Panel heater for applications with high humidity and minimum temperature less than -5 °C
- Fans for high power applications
- Flaps at top of panel allow release of discharge gases to ceiling ventilation systems

3.3 Resistance to Internal Arc Faults

An arc fault is a high power discharge of electricity between two or more conductors. In the event of an arc fault the energy released in the fault rapidly vaporises metal, blasting molten metal and expanding plasma outward with extreme force.

L-Series switchgear panels have passed arc fault tests for the entire range of panel enclosures. During an arc fault, expansion of gases is contained within the solid locking door and heavy double layer panel walls. Pressure release flaps at the top of panel direct the explosion upwards. Duct kits may be installed to direct the gases outside.

3.4 Safety Features

L-Series switchgear panels have been designed with a number of safety interlocks to protect both personnel and equipment.

Panel Internal Interlocks

- Phase cassette compartment interlocks

The phase cassette compartment is located at the bottom of the soft starter panel only.

- The compartment's door cannot be opened if the earth switch is open.
- The withdrawable phase cassette can only be moved when the switching apparatus is in the test/disconnected position and racked out with the earth switch closed.
- When the phase cassette is in the intermediate position (ie neither in the test/disconnected or service positions), both switching apparatus and earth switch are mechanically interlocked and cannot be operated.

- Cable/bottom compartment interlocks

The cable/bottom compartment is located at the bottom of all standard panels.

- If the panel has an earth switch installed, the compartment's door cannot be opened if the earth switch is open. Inter-panel interlocks can also be configured to lock the door when an earth switch in another panel is open.
- The switching apparatus can be powered up only when the cable compartment's door is closed and earth switch (if installed) is open.

- Switching Apparatus Interlocks

The switching apparatus compartment is located in the middle of all panels.

- The switching apparatus cannot be racked-in if the compartment's door is open. The compartment's door cannot be opened if the switching apparatus is in the service or in an intermediate position.
- Connecting and disconnecting the control wiring plug is only possible in the test/disconnected position of the withdrawable part.
- If the earth switch is in a closed position, the withdrawable part cannot be moved from the test/disconnected position to the service position.

Locks

- Doors locks

Some compartments are equipped with locks on door handles. To open a compartment door:

- Use the key to open the lock on the compartment door, then draw the lock handle out and to the left.
- Lift the door handle to disengage the latching mechanism and open the door.

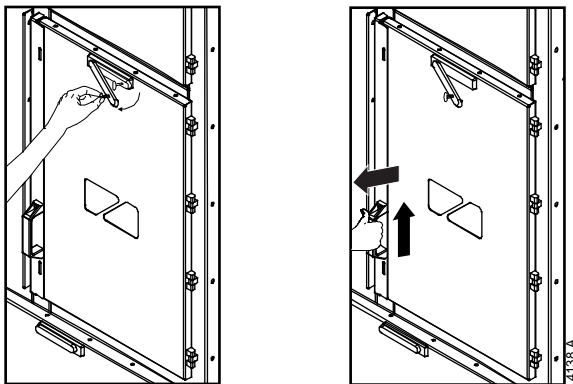

- Safety locks

For added protection, padlocks can be used to restrict access to high voltage areas of the panel.

- A padlock can be used to lock the metallic shutters in the switching apparatus compartment when the device has been removed.
- Padlocks can be used to lock the sliding brackets used to cover the apertures for racking and operating the switching apparatus.

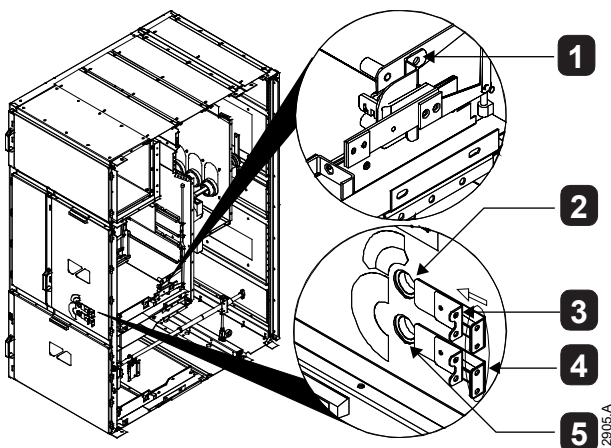

1	Hole for padlock
2	Change operation state *
3	Hole for padlock
4	Sliding brackets
5	Rack in/out

* Only available for switchgear panels fitted with TEL ISMD.

3.5 General Technical Data

Supply

Rated Voltage (U_r)	12 kV
Rated Frequency (fr)	50/60 Hz
Rated lightning impulse withstand voltage (U_p)	75kV (95kV on request)
Rated power frequency withstand voltage (U_a)	28kV (42kV on request)
Rated short-time withstand current (symmetrical RMS) (I_k)	31.5 kA
Rated duration of short circuit current (t_k)	4 s
Internal Arc Classification (ALFR)	31.5kA for 1 s
Rated horizontal busbar current	630 A, 1250 A, 1600 A, 2000 A
Rated dropper current	630 A, 1250 A, 1600 A, 2000 A

Environmental

Degree of Protection	
630 A, 1250 A	IP4X
1600 A, 2000 A	IP3X
Operating Environment	
IEC60721-3-3: IE34: Climatic 3K4	-5 °C to 40 °C, with derating to 55 °C
Humidity	5% to 95% Relative Humidity
Storage Environment	
IEC60721-3-1: IE12: Climatic 1K3	-5 °C to 40 °C
Humidity	5% to 95% Relative Humidity
Operating Altitude	0 - 1000 m, above 1000 m with derating

EMC Emission

Equipment class (EMC)	Class A
Conducted radio frequency emission	10 kHz to 150 kHz: < 120 - 69 dB μ V 0.15 MHz to 0.5 MHz: < 79 dB μ V 0.5 MHz to 30 MHz: < 73 dB μ V
Radiated radio frequency emission	0.15 MHz to 30 MHz: < 80-50 dB μ V/m 30 MHz to 100 MHz: < 60-54 dB μ V/m 100 MHz to 2000 MHz: < 54 dB μ V/m

This product has been designed as Class A equipment. Use of this product in domestic environments may cause radio interference, in which case the user may be required to employ additional mitigation methods.

EMC Immunity

Electrostatic Discharge	6 kV contact discharge, 8 kV air discharge
Radio Frequency Electromagnetic Field	80 MHz to 1000 MHz: 10 V/m
Fast Transients 5/50 ns (main and control circuits)	2 kV line to earth, 1 kV line to line
Surges 1.2/50 μ s (main and control circuits)	2 kV line to earth, 1 kV line to line
Voltage dip and short time interruption	5000 ms (at 0% nominal voltage)

Standards Approvals

C✓	EMC requirements
CE	EMC EU Directive

Standards Referenced

Switchgear and apparatus	IEC62271-1 EC62271-200
Internal arc resistance	IEC62271-200
Electromagnetic capability (compliant with EU Directive 89/336/EEC)	
EMC Emissions	IEC 60947-4-2 Class A
EMC Immunity	IEC 60947-4-2
Insulation	
Degree of Protection	IEC60529
Drilled holes and screw connections for busbars	DIN43673-1
Groups of environmental parameters and their severities	
Storage	IEC60721-3-1
Transportation	IEC60721-3-2 IEC60068-2-32
Stationary use at weather-protected locations	IEC60721-3-3
Software	MISRA

Section 4 Panel Specifications

AuCom switchgear panels are categorised as follows:

- Soft starter panel (SSP)
- Standard panels



NOTE

Panel layout views depict only typical panel configuration options.

4.2 Panel Arrangement

All L-Series switchgear panels are similar in configuration and are compartmentalised for isolation and electrical switching between components.

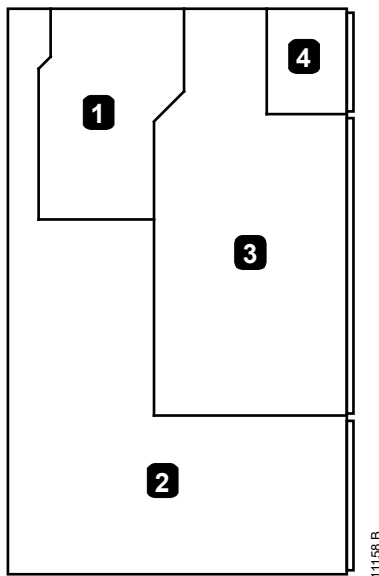

1	Busbar compartment
2	Cable compartment
3	Switching compartment
4	Low voltage compartment

Busbar Compartment

The busbar compartment houses the main busbar system, which is connected to the fixed upper isolating contacts of the main switching apparatus by means of branch connections. The main busbars are made of high conductivity copper. The busbar compartment of each panel is isolated from the busbar compartments of the neighbouring compartments.

Single or parallel busbar configuration is used depending on the current rating.

Cable Compartment

The cable compartment houses some of the following components:

- Branch connections
- Earthing busbar
- Earth switch
- Power cables
- Surge arrestors
- Instrument transformers (current transformers, voltage transformers)

The soft starter panel (SSP) cable compartment contains fixed contacts for the connection of the soft starter phase cassette (IP00).

Switching Compartment

The switching compartment houses the bushing insulators containing fixed contacts for the connection of the switching apparatus to the busbar and cable compartment. The bushings are single-pole type and are made of cast resin. They are covered by metallic shutters.

The metallic shutters operate automatically during movement of the switching apparatus from the test/disconnected position (racked-out) to the service position (racked-in) and vice versa. Shutters may be locked if required.

The position of the switching apparatus can be seen from the front of the panel through an inspection window.

Low Voltage Compartment

The low voltage compartment provides safe isolation from any medium voltage equipment. This is used for installation of low voltage control equipment, including DIN rail mounted terminal blocks. Equipment can be panel mounted on the LV compartment door for customer interfacing.

- Soft Starter Low Voltage Sections

The soft starter panel includes two sections for low voltage (LV) wiring:

- An upper LV section for protection and control supply distribution .
- A lower LV section for wiring the MVX Controller.

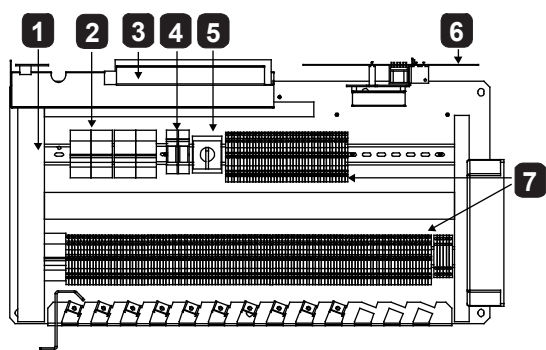

Upper LV section

1	Conduit for LV wiring
2	Miniature circuit breakers (MCB)
3	Switch mode power supply (SMPS)
4	Surge protector
5	Soft start/DOL switch
6	Power supply isolator PCB
7	Terminal blocks - double tier

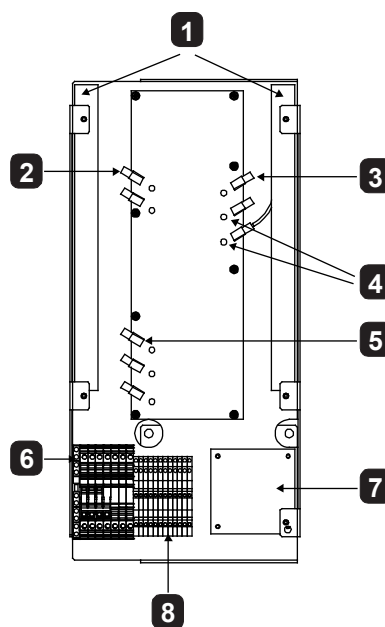

Lower LV section

1	Conduit for LV wiring
2	Fibre optic connectors for MVX Controller
3	Gate firing fibre optic connectors
4	Fibre optic LED
5	Non-conduction feedback fibre optic connectors
6	Current transformer test block (TB1)
7	Earth leakage PCB
8	Terminal blocks - double tier

4.3 Soft Starter Panel (SSP)

The soft starter panel is designed to house the primary soft starter components and associated switchgear.

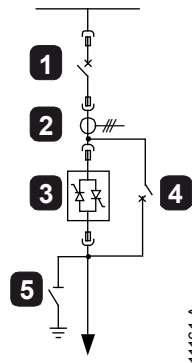
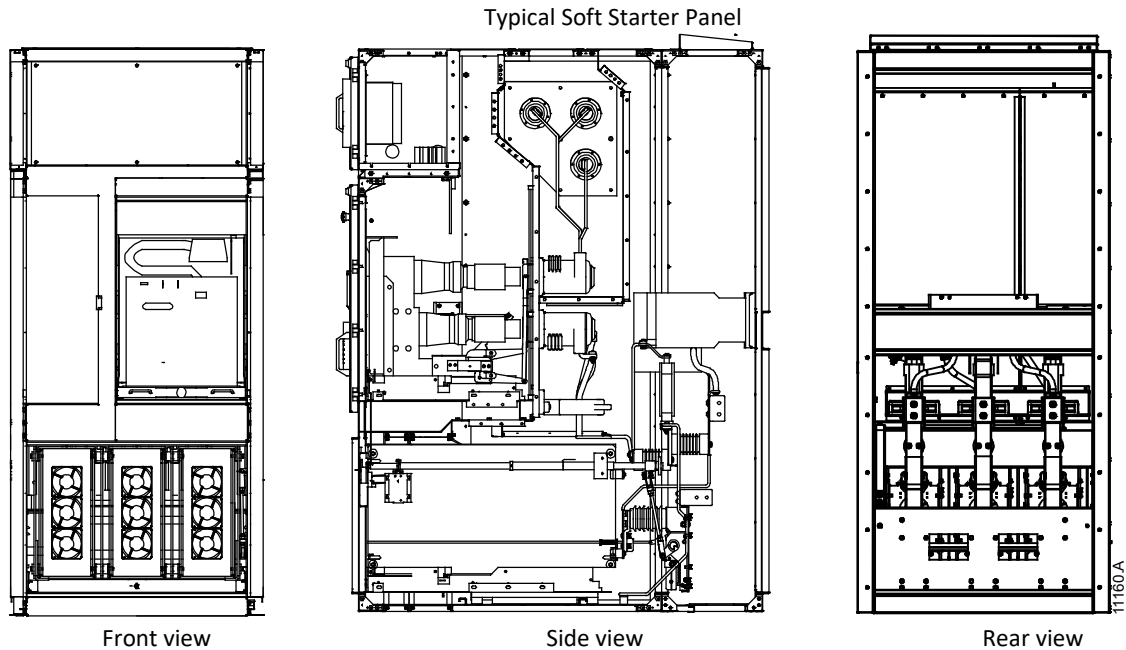

1	Main switching apparatus
2	Current transformer
3	Phase cassette
4	Bypass switching apparatus
5	Earth switch

	12 kV		> 12 kV
	0 ~ 160 A	160 ~ 600 A	0 ~ 600 A
Width (mm)	1000	1000	1000
Depth (mm)	1600	1600	1600
Height (mm)	2200	2200	2200
Min. height without gas exhaust ducts (mm)	3200 ¹	3200 ¹	3200 ¹
Earth switch	0/1	0/1	0/1
Sets of current transformers	1 ²	1 ²	1 ²
Fused contactor	1 ³	0	0
Circuit breaker	0	1 ⁴	1 ⁴
Protection relay	0/1 ⁵	0/1 ⁵	0/1 ⁵
RTD module	0/1	0/1	0/1
Communications protocol	Modbus, Profibus, DeviceNet	Modbus, Profibus, DeviceNet	Modbus, Profibus, DeviceNet
Surge protection	1	1	1
Weight (kg)	1286	1286	1286

¹ Allow at least 1 metre between top of panel and ceiling if gas exhaust ducts are not used.

² The class and burden of the current transformer are designed for the MVX.

³ Includes one main contactor with fuses (withdrawable) and one bypass contactor (fixed).

⁴ Includes one main circuit breaker (withdrawable) and one bypass circuit breaker (fixed).

⁵ Required for circuit breaker installations.

4.4 Standard Panels

AuCom standard panels are designed to be installed individually or connected to an AuCom soft starter panel (SSP) in a panel line-up. Standard panels may be equipped with customisable switchgear options and are available as follows:

- Incomer Feeder Panel (IFP)
- Direct Incomer Panel (DIP)
- Bus Coupler Panel (BCP)
- Bus Riser Panel (BRP)
- Metering Panel (MTP)
- Direct On-line Panel (DOP)

Incomer Feeder Panel (IFP)

As the name implies, this panel configuration serves two purposes:

- As an incomer panel. This switches the incoming main supply onto the common horizontal busbar system of a metal-enclosed switchgear arrangement
- As a feeder panel. This switches the main supply from the common horizontal busbar system of a metal-enclosed switchgear arrangement onto a specific feeder circuit.

The enclosure will always have a main circuit breaker (normally withdrawable), housed in its own compartment of the panel. An earth switch at the cable termination end of the circuit provides isolation during shutdown and maintenance. Interlocking ensures that the earth switch cannot be closed until the main circuit breaker is open and racked-out into the test position. Current transformers are fitted to interface with a protection relay for circuit breaker trip operation.

Depending on the required function, voltage transformers can be supplied. These can be 3-phase or single phase, either fixed or withdrawable style. A variety of low voltage equipment is used, which is mounted in its own segregated compartment, situated at the top-front of the enclosure assembly.

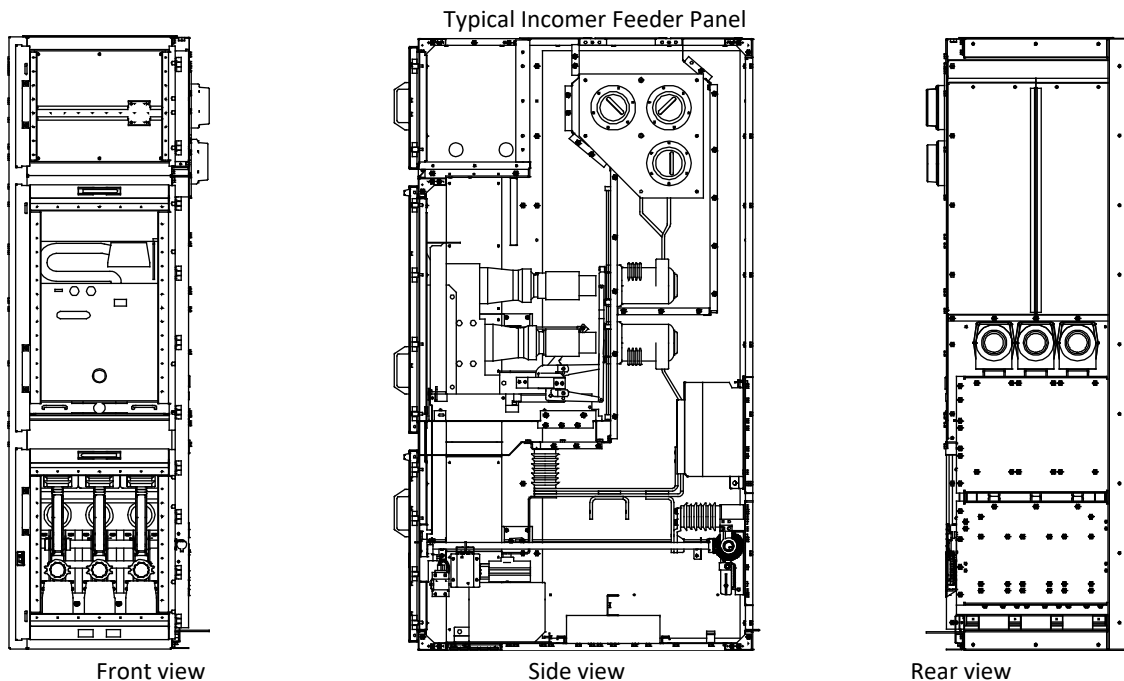

11163.A

Section 5

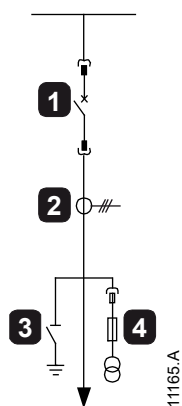

1	Circuit breaker (withdrawable)
2	Current transformer set
3	Earth switch
4	Voltage transformer (fused and withdrawable)

	630 ~ 1250 A	1250 ~ 2000 A
Width (mm)	650	800
Depth (mm)	1200	1200
Height (mm)	2200	2200
Min. height without gas exhaust ducts (mm)	3200 ¹	3200 ¹
Earth switch	0/1	0/1
Sets of current transformers	1 ²	1 ²
Voltage transformers	Fixed or withdrawable (with fuses)	Fixed or withdrawable (with fuses)
Voltage indication	0/1	0/1

¹ Allow at least 1 metre between top of panel and ceiling if gas exhaust ducts are not used.

² Current transformers are available in multi-core configurations. Depending on the class and burden of the installation, transformers with up to three cores may be supplied by AuCom.

Section 5 Receiving and Storage

All AuCom switchgear panels are individually packed and securely braced for shipment. Depending on the number of individual switchgear sections, it may be necessary to ship the switchgear in several sections to facilitate handling.

Panels may include relatively delicate equipment (protection relays, transformers, bushings, etc). Handle all sections with care when unloading. Some electrical components (eg switching apparatus, soft starter phase cassette, etc) may be shipped separately and then installed on-site. The shipping inventory should account for all individual components.

5.1 Receiving

Inspect equipment as soon as possible for any damage that may have occurred during transit. Before accepting delivery, examine packaging for any signs of damage. A damaged package may indicate that the panel and internal components may also be damaged.

Check that the shipping manifest accounts for all equipment delivered. Any missing or damaged equipment should be noted on the freight bill and the carrier notified immediately. A record of the missing or damaged equipment should also be sent to AuCom.

**NOTE**

Avoid using heavy or sharp-edged tools while unpacking, as these may damage the equipment. Use nail pliers to separate all four sides of the wooden packaging box.

5.2 Storage

If immediate installation is not possible, the switchgear should be stored in its original packaging in a clean and dry area indoors. Always store switchgear upright on its wooden pallet to keep it off the floor and allow air to pass under it freely.

**NOTE**

Switchgear can be stored for a maximum of 12 months from the date of packaging as the quality of the packaging material degrades over time.

The following general precautions should be followed when storing switchgear indoors:

- Do not unpack the switchgear panel, soft starter phase cassette or other components until they are ready for installation.
- If electrical components such as circuit breakers are to be stored for more than three months in humid conditions, space heaters should be used in the storage area to limit condensation. Switchgear panels with in-built anti-condensation heaters may be powered from an external supply during storage.
- Rats and other vermin may cause considerable damage and periodic inspection is necessary to minimise the danger they pose.
- Ensure the floor of the storage area is smooth and level to prevent mechanical strain to the structure and components.

Section 6 Installation

Site installation of switchgear panels should only be carried out by specially trained and skilled personnel. The switchgear location must be adequately prepared with wall openings, ventilation ducts and cabling connections to the power supply.



CAUTION

The maximum tolerance for switchroom floor is ± 2 mm per metre (with a maximum of ± 5 mm over the entire panel line-up). Failure to comply with these recommendations may impair the electro-mechanical functionality of some components and the structural integrity of the entire panel system.

Switchgear panels are fitted with a base for mounting panels directly to the switchroom floor, it is recommended that buried steel channels are installed in a level concrete floor to support the equipment. The surfaces of the buried steel channels should be level with the finished floor and aligned with each other prior to final anchoring. The switchgear panel's base should be evenly supported by the concrete floor. If the switchgear panel is raised above the floor level by the mounting channels, the entire base frame must be supported at the same level. If the switchgear panel is part of a line-up, all channels must be level and aligned with each other.

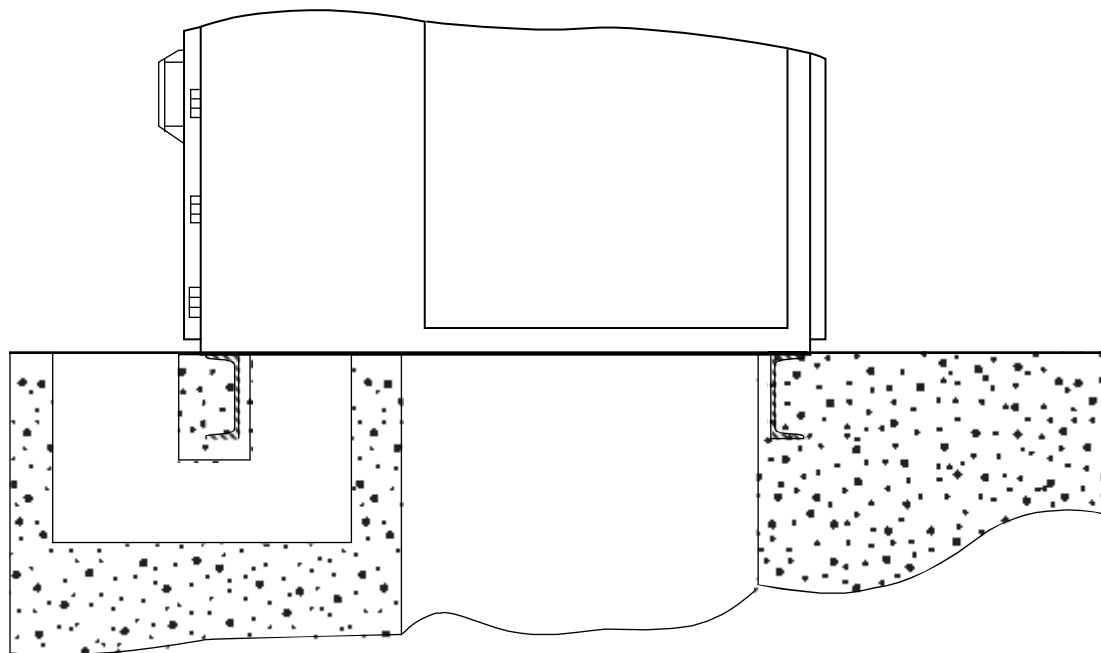

14139.A

The figure below illustrates typical methods for anchoring switchgear panels to buried steel channels.

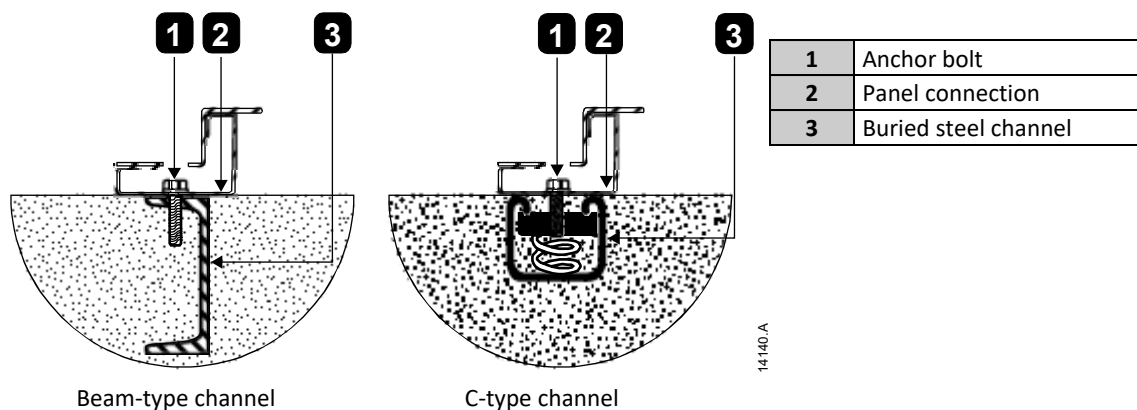

14140.A



NOTE

Anchor bolts, channels, and other materials are not supplied as part of the switchgear arrangement.

Fastening Panels to the Foundation

Switchgear panels must be fastened securely to a level floor which has been adequately prepared.

- Soft Starter Panel (SSP)

It is recommended that all five bolt holes at the front and all three bolt holes at the rear are used to securely bolt the panel to the floor using M12 bolts.

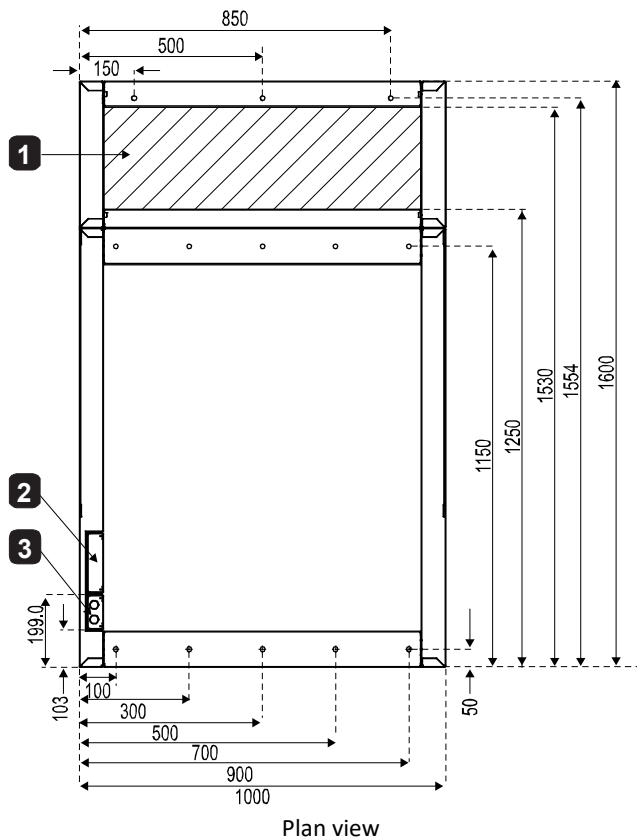

1	Removable non-ferrous gland plate
2	Low voltage wiring duct (for AuCom components only)
3	Low voltage wiring duct for customer wiring

Wiring and cabling of the soft starter is accommodated as follows:

- A removable non-ferrous gland plate for motor and/or mains supply cables.
- A low voltage wiring cable duct for customer wiring.

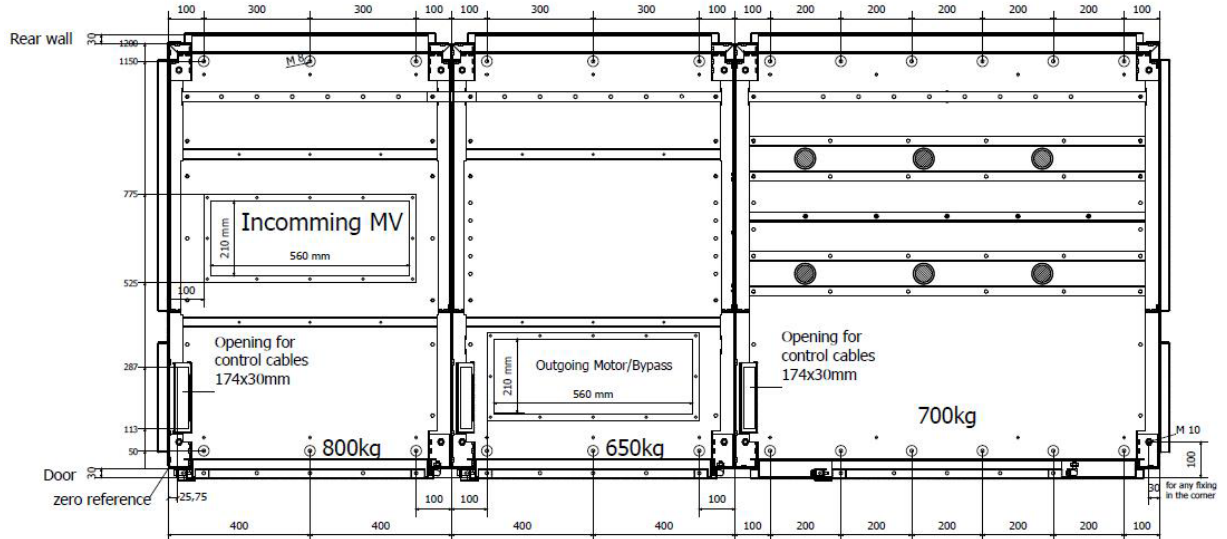

- Standard Panels

It is recommended that all three bolt holes at the front and all three bolt holes at the rear are used to securely fasten the panel to the floor.

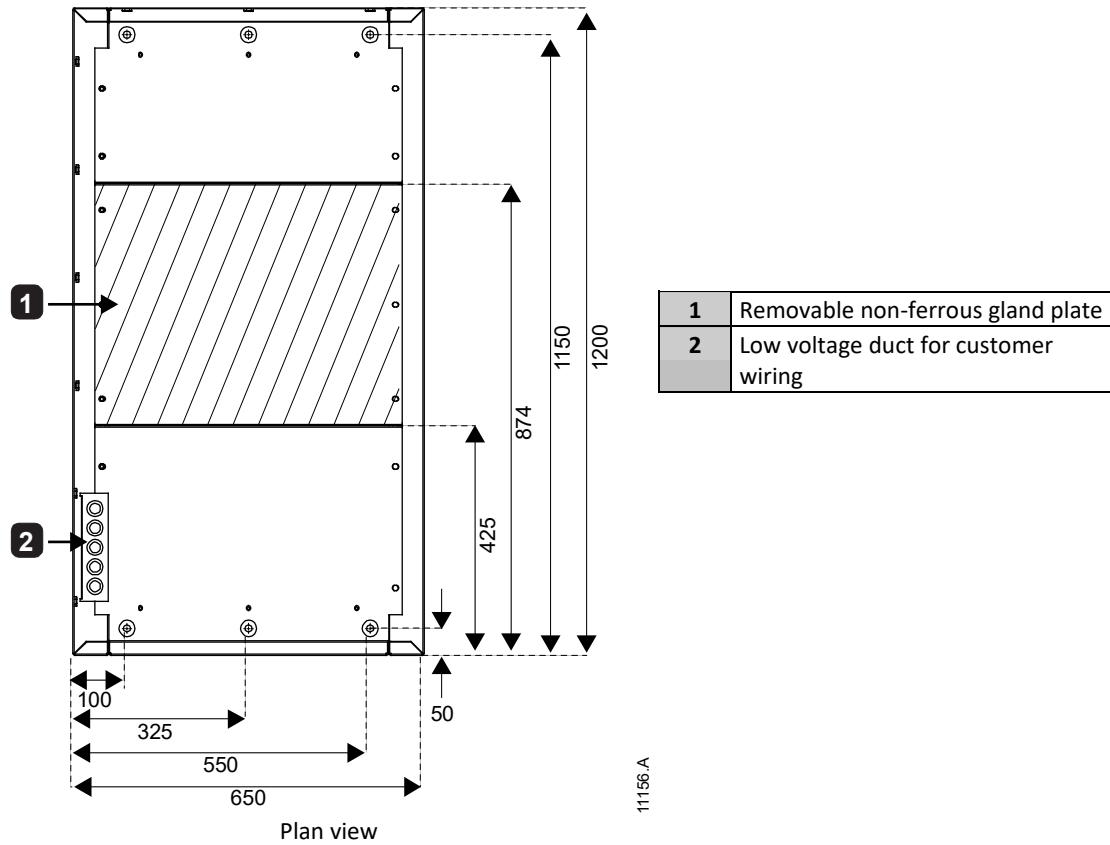

Wiring and cabling of the panel is accommodated as follows:

- A removable non-ferrous gland plate for medium voltage cables.
- A low voltage wiring cable duct for customer wiring.

6.2 Clearance Requirements

While installing AuCom switchgear panels, ensure that minimum clearance requirements are met.

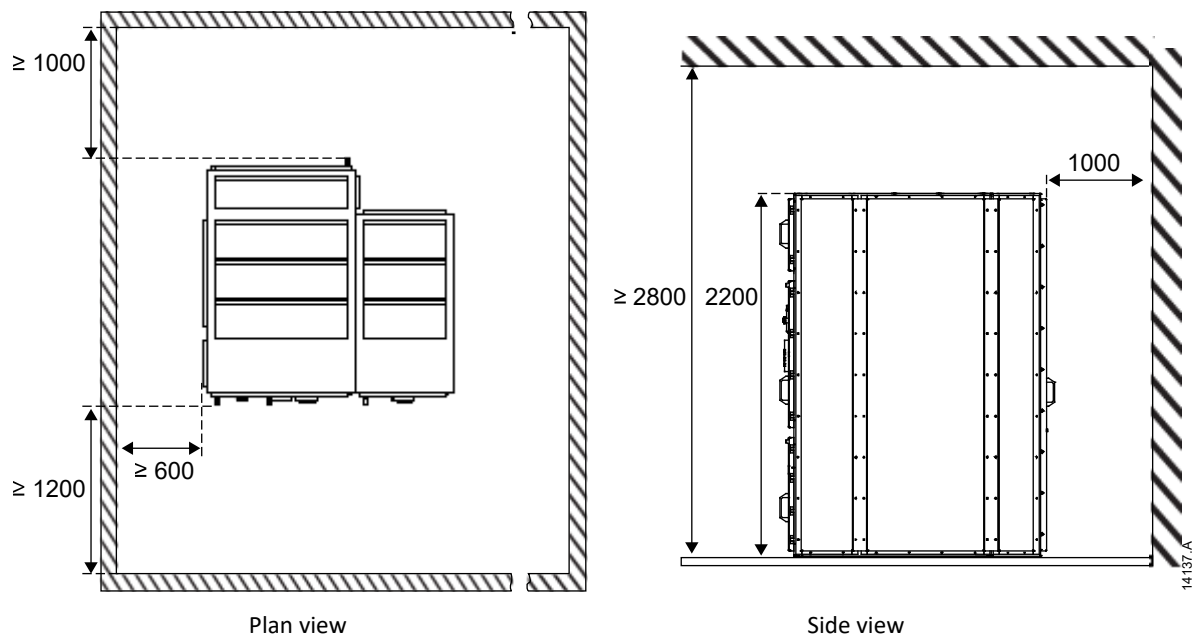

If the distance from the rear of the panel to the wall is greater than 1 m, the recommended ceiling height is 2.8 m or greater. If the distance from the rear of the panel to the wall is less than 1 m, the recommended ceiling height is 3 m or greater.



NOTE

Standard panels may be mounted closer to the wall from the rear if required. Consult AuCom if closer wall mounting is required.

6.3 Lifting and Moving

Switchgear panels can be moved in a number of ways. However, care should be taken to protect the panel sections or enclosed electrical components from damage during moving. Provision has been made along the sides of the panel to fit lifting lugs. Lifting cables can then be fitted for lifting with a crane.



NOTE

The recommended method of moving the switchgear is using a crane. If height constraints prevent the use of a crane, a forklift or jack may be used before removal of the wooden pallet.

Fastening Lifting Lugs to the Panel

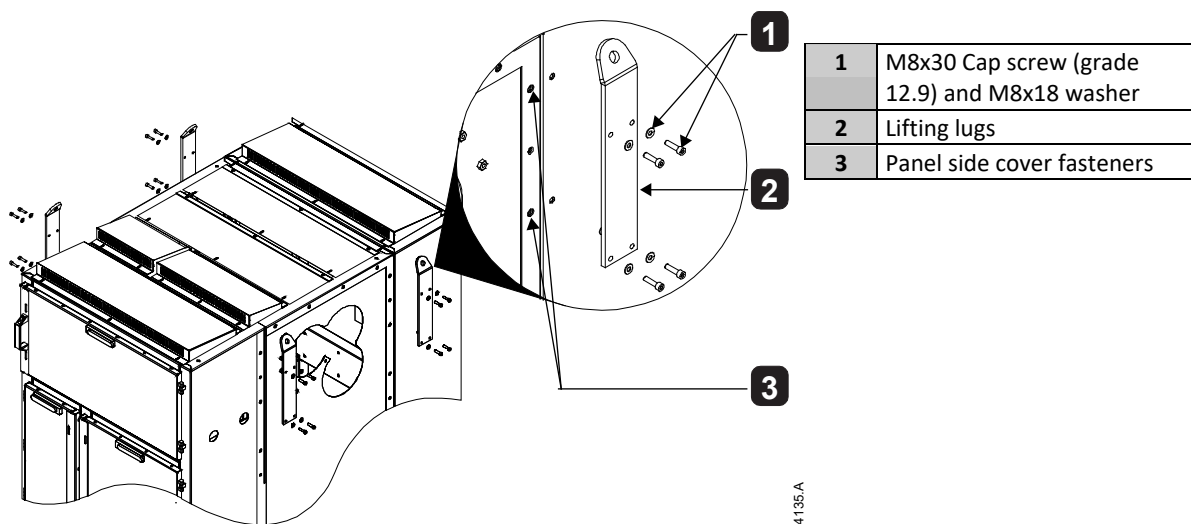

1. Locate and unscrew the four screws holding the side covers to the panel as indicated above. Repeat for all four side covers.
2. Align the lifting lugs to the sides of the panel making sure that the lifting eyes bend inward, towards the centre line.
3. Use four M8x30 grade 12.9 cap screws and M8x18 washers (tightened to a torque of 35 Nm) to fasten each lifting lug to the panel.
4. Fit lifting cables through the eyes of the lugs and connect all four cables at the top to form a sling.



NOTE

MXV Lifting Kit (part number: 995-13297-00) is required for this operation.



NOTE

If side covers are not fitted and bolting holes do not have threaded inserts, use hex nuts to fasten bolts.

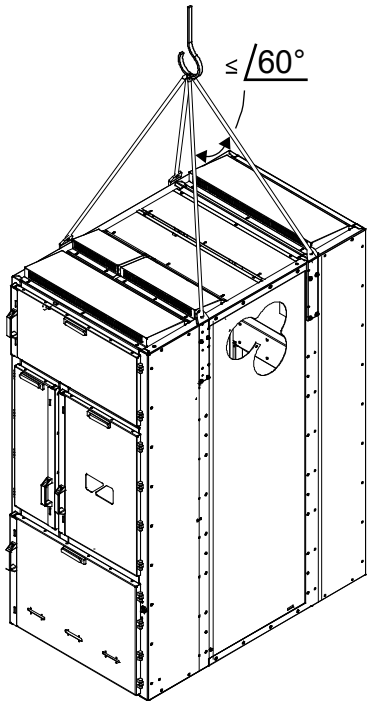

14136.A

Before moving the switchgear:

- Ensure that the crane is tall enough that the angle formed between the arms of the sling is no more than 60° when viewed from the front or rear of the panel.
- Always use lifting equipment that is rated for the prescribed load. Only use a crane of sufficient lifting capacity to bear the weight of the equipment to be lifted.
- Identify the centre of gravity, physical dimensions, weight etc.
- Plan the path along which the switchgear will be moved, ensuring that it is free from obstructions.
- If moving more than one unit at a time, disconnect bus connections between panels to prevent damage to the busbars.
- Ensure that adequate precautions have been taken to protect personnel before moving the panel.
- Only use AuCom recommended bolts and metal connectors. Never replace or modify a manufactured lifting component.

6.4 Busbar Installation

Horizontal busbars are to be connected to the main busbar system with bolts as indicated below. Refer to *Bolting Torques* on page 23, for the correct bolt tightening torque.

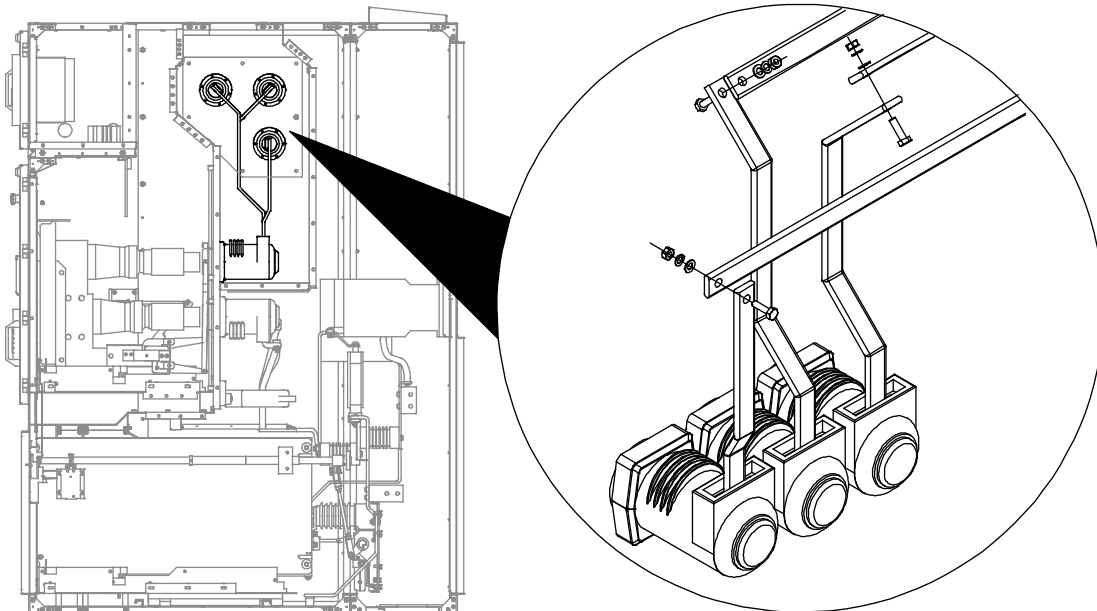

Typical 630 A busbar

11185.A

Horizontal busbar rating A	Withstand current kA-4s
630	31.5
1250	31.5
1600	31.5
2000	31.5



NOTE

Applicable drawings showing busbar configuration and bolting will be provided by AuCom.

6.5 Earth Termination

An earth bar is located at the rear of the panel.

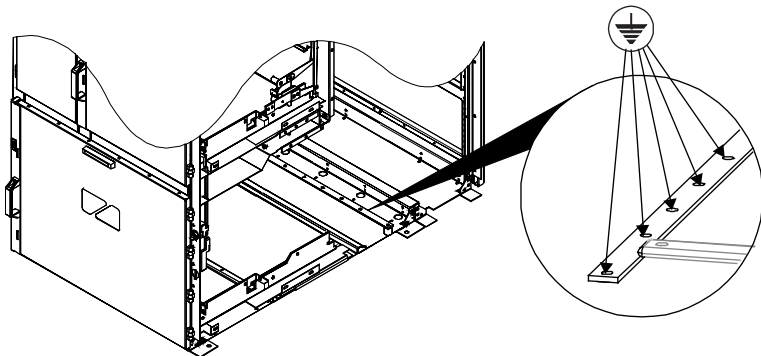

An earthing wire may be terminated anywhere along this bar using M10 high tensile grade 8.8 threaded fasteners for all terminations.

6.6 Assembling the Switchgear Line-up

Switchgear panels may be connected together to form a panel line-up. Assembling the panel line-up includes the following operations:

- Aligning the panels
- Fastening the panels together
- Connecting the earth bus

Aligning the panels

Switchgear sections may be shipped individually to facilitate loading and transportation. At the installation site, the shipping sections must be securely bolted together to form the switchgear line-up. Align the shipping sections side by side on the foundation as follows:

- Remove all packaging material from the first switchgear section to be installed, except the wooden pallet on which each panel is mounted. The wooden pallet protects the switchgear and reduces risk of damage during moving.
- Move the panel to the desired location (refer to *Lifting and Moving* on page 16 for details). Remove the bolts and discard the wooden pallet.
- Line up the bolt holes in the base frame of the switchgear with the holes in the foundation steel channels (refer to *Fastening Panels to the Foundation* on page 14 for details).
- Once the individual panels have been placed in position, use a level or plumb line to make sure the panel line-up is level both across its depth and along its length. Draw an installation baseline the entire length of the complete switchgear.

Install the other switchgear sections following the above steps, with reference to the installation base line.

Fastening the panels together

Once the sections of the switchgear line-up have been aligned exactly, fasten adjacent panels together securely. Use M8x20 screws with Belleville washers to fasten panels together using the tie bolt holes.

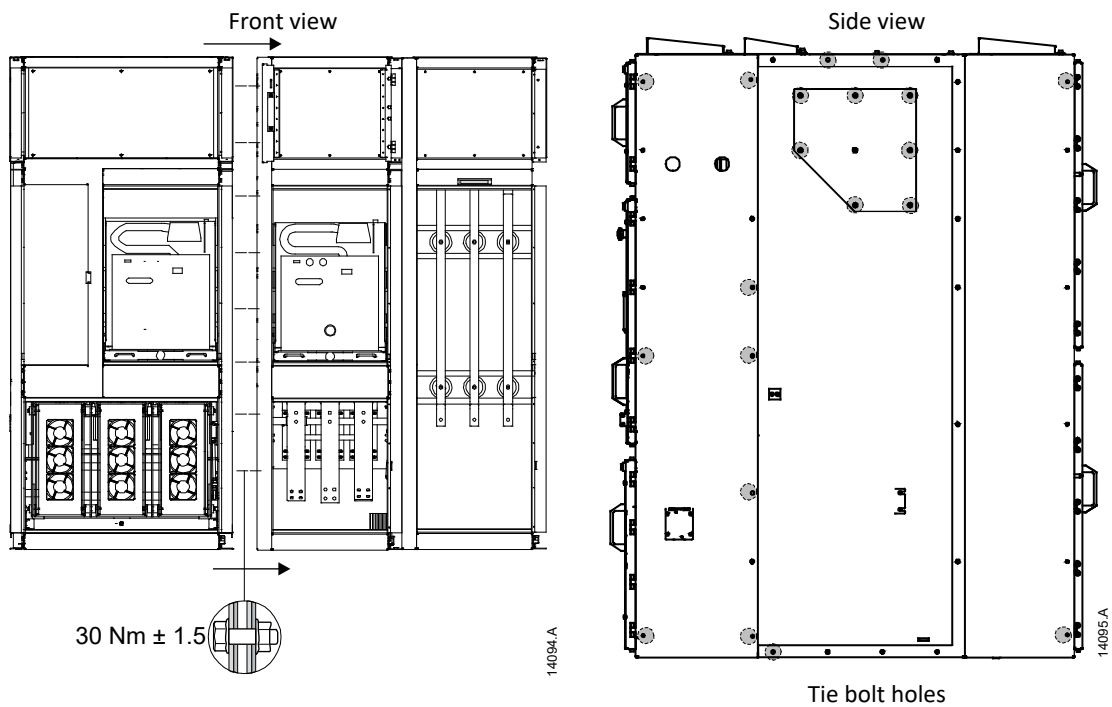

Connecting the earth bus

The standard earth bus runs the entire length of the switchgear line-up. The earth bus in the switchgear line-up is assembled in sections, with a bus joint in each panel. Terminals are provided on each joint for connecting the earth bus to the earthing system of the switchgear building. Each panel is equipped with the facility to connect to the building earth (refer to *Earth Termination* on page 18 for more information).

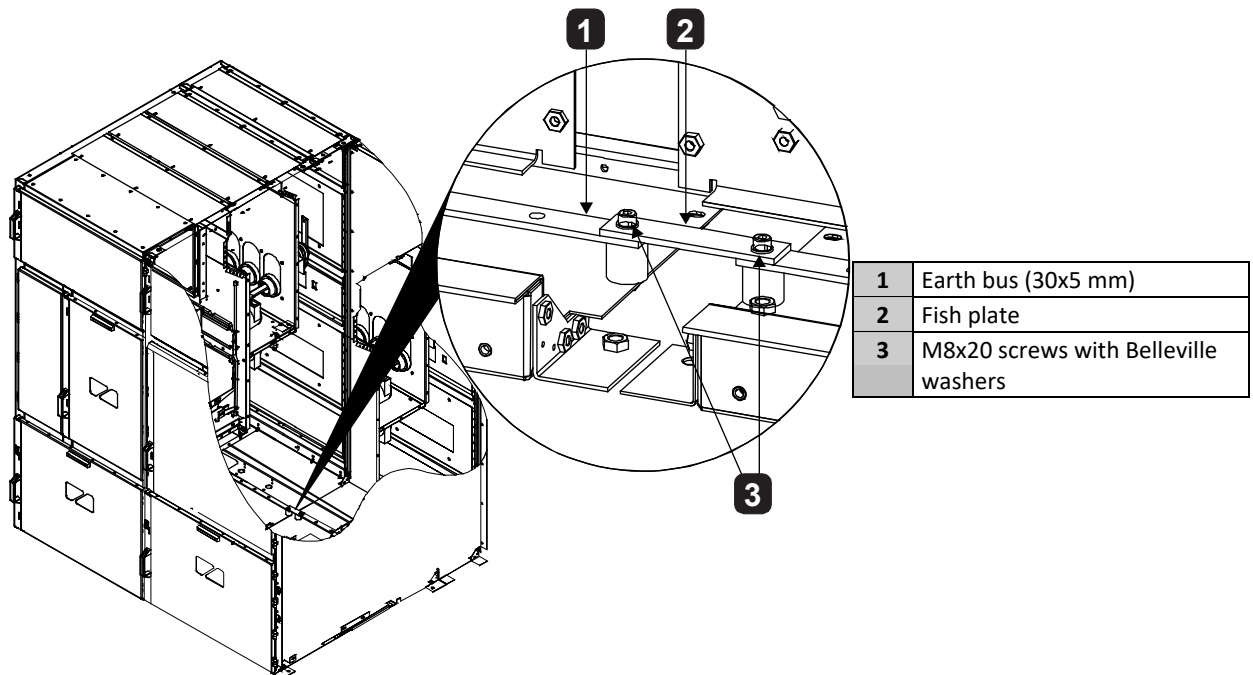

To connect the earth bus between panels in a line-up:

1. Slip the fish plate through the aperture in the panel.
2. Align the bolt holes of the splice plate with those in the bus joint of each panel and fasten together securely.

Section 7 Operation and Maintenance



NOTE

Always stop (or power down) the L-Series switchgear panel before conducting any maintenance.



NOTE

Do not force interlocks, switches and other electro-mechanical devices. Read this manual carefully and understand the system operation prior to use.

7.1 Earth Switch Operation

The earth switch is fitted in the cable/bottom compartment. It is operated by a hexagonal actuating shaft. This shaft is rotated to operate the earth switch using a brace (supplied).

The aperture through which the brace operates the earth switch is protected by a metal shutter. This shutter must be pushed down to access the aperture.

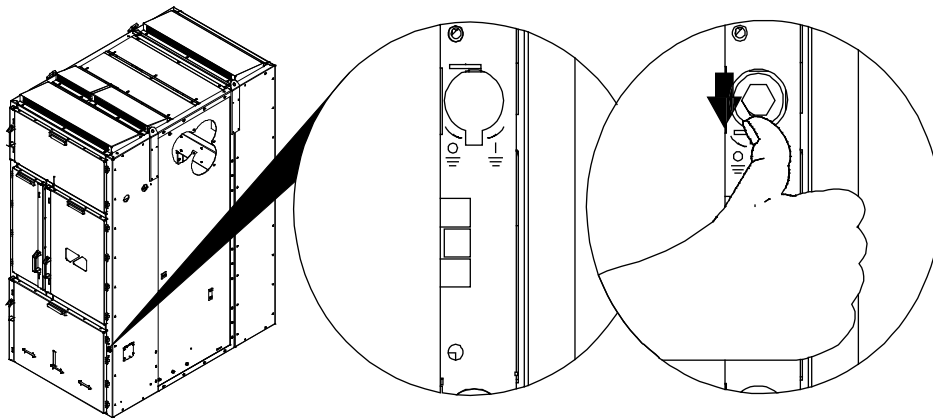

14219 A

The direction of operation of the earth switch is indicated on the label below the aperture:

- Close the earth switch by rotating the brace in the anticlockwise direction (indicated "I") until the sound of the switch engaging is heard.
- Open the earth switch by rotating the brace in the clockwise direction (indicated "0") until the sound of the switch disengaging is heard.



NOTE

The shutter covering the earth switch's aperture cannot be moved when the main switching apparatus is in the service position.

Earth switch auxiliary contacts

Auxiliary earth switch contacts are provided for control of external devices in tandem with the earth switch. The auxiliary switch has three normally open (N/O) contacts which are coloured red and two normally closed (N/C) contacts which are coloured green.

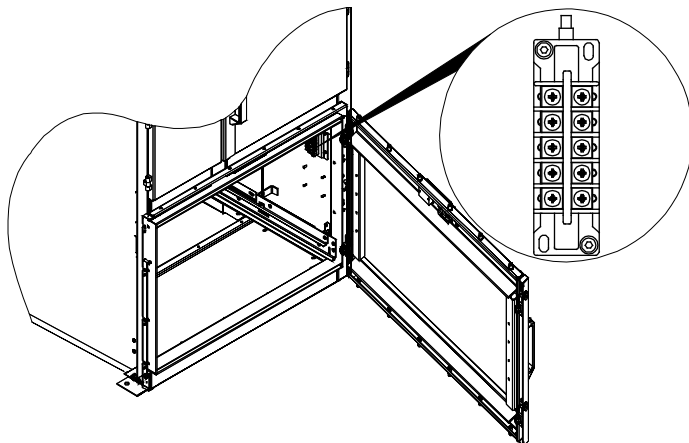

14220 A

Normally Open (N/O)	21-22, 31-32, 41-42
Normally Closed (N/C)	51-52, 61-62

7.2 Main Switching Apparatus Operation

The main switching apparatus can be a fused contactor or vacuum circuit breaker (contact AuCom for more information). The switching apparatus must be racked in until its contact terminals connect with the terminals in the switching apparatus compartment. Once the switching apparatus has been completely racked in, the device can be put into the service position.

Both, changing of operation state and racking in/out of the switching apparatus are carried out with the door closed. The switching apparatus compartment's door is provided with apertures for carrying out these operations.

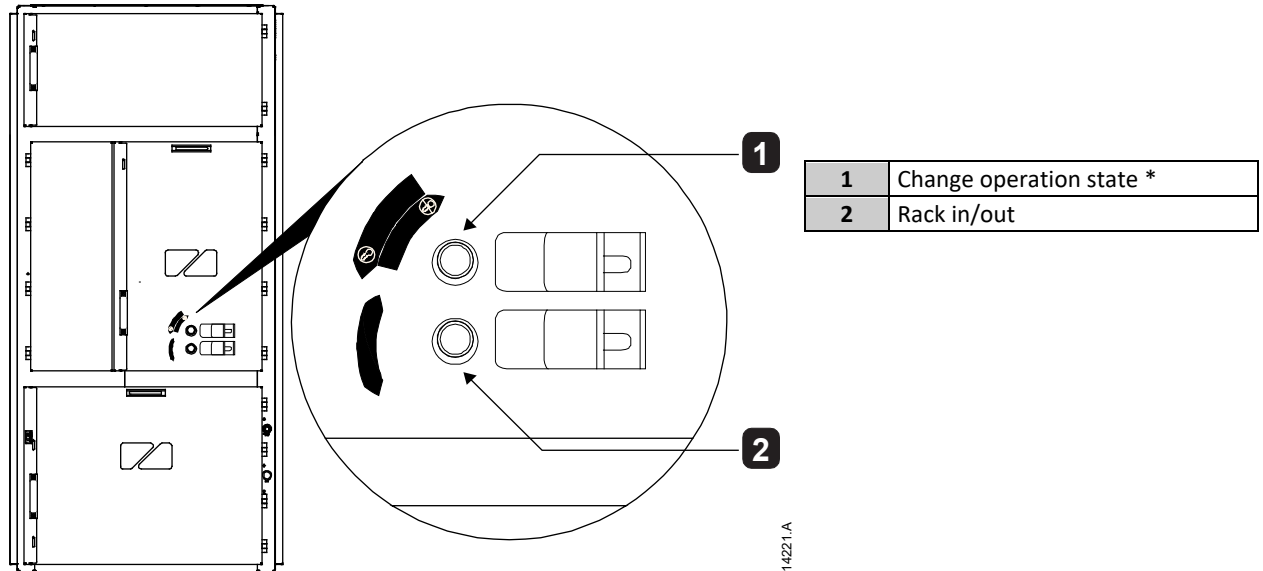

* Only available for switchgear panels fitted with TEL ISMD.



NOTE

Refer to the appropriate switching apparatus documentation for specific operating instructions.

7.3 Access to Compartments

Access to phase cassette compartment

To open the phase cassette compartment:

1. Power-down the soft starter.
2. Make sure that the control voltage supply to the switching apparatus has not been disconnected. This will enable the switching apparatus to apply signalling voltage to disable the electromagnetic lock.
3. Unlock the shutter covering the aperture. Use the brace to turn the switching apparatus into the test/disconnected position.
4. Use the crank in the racking aperture, turning it counter-clockwise until it cannot be racked out further (approximately 20 turns of the racking arm).
5. With power disconnected and switching apparatus open and racked out, the shutter covering the earth switch aperture is unlocked. Use the brace to close the earth switch. Refer to *Earth Switch Operation* on page 20 for more information.
6. Unlock and open the door. Refer to *Doors locks* on page 5 for more information.

Disconnect control wiring and the fibre-optic connectors before carrying out any operations. Refer to the *MVX User Manual* for more information.

Access to cable/bottom compartment

To access the cable/bottom compartment:

1. Ensure that main power supply has been disconnected.
2. Make sure that the control voltage supply to the switching apparatus has not been disconnected. This will enable the switching apparatus to apply signalling voltage to disable the electromagnetic lock.
3. Unlock the shutter covering the aperture. Use the brace to turn the switching apparatus into the test/disconnected position.
4. Use the crank in the racking aperture, turning it counter-clockwise until it cannot be racked out further (approximately 20 turns of the racking arm).

5. With power disconnected and switching apparatus open and racked out, the shutter covering the earth switch aperture is unlocked. Use the brace to close the earth switch. Refer to *Earth Switch Operation* on page 20 for more information.
6. Unlock and open the door. Refer to *Doors locks* on page 5 for more information.

Access to switching apparatus compartment

To access the switching apparatus compartment:

1. Make sure that the control voltage supply to the switching apparatus has not been disconnected. This will enable the switching apparatus to apply signalling voltage to disable the electromagnetic lock.
2. Unlock the shutter covering the aperture. Use the brace to turn the switching apparatus into the test/disconnected position.
3. Use the crank in the racking aperture, turning it counter-clockwise until it cannot be racked out further (approximately 20 turns of the racking arm).
4. Unlock and open the door. Refer to *Doors locks* on page 5 for more information.

Disconnect the control wiring plug of the switching apparatus before carrying out any operations. Refer to the switching apparatus's user manual for more information.

7.4 Maintenance

The soft starter is maintenance free. For the maintenance of the VCB, earthing switch and disconnecting switch, refer to the manual supplied by the manufacturer.

Section 8 Appendix

8.1 Bolting Torques

Bolt size*	Torque (Nm)
M5	5
M6	7
M8	13
M8 (nylon)	2
M10	20 ~ 25
M12	30

*Steel bolts according to EN ISO 898 class 8.8 (800 N/mm²) or higher are recommended.

New Zealand

123 Wrights Road, PO Box 80208, Christchurch 8440, New Zealand

T +64 3 338 8280 **F** +64 3 338 8104

China

203-1 JH Plaza, 2008 Huqingping Road, Shanghai 201702, China

T +86 21 5877 5178 **F** +86 21 5877 6378

Germany

Borsigstraße 6, 48324 Sendenhorst, Germany

T +49 2526 93880 0 **F** +49 2526 93880 100

Middle East

Al Thanyah Fifth, Mazaya Business Avenue BB2, Jumeirah Lakes Towers, Dubai, UAE

T +971 4 430 7203

North America

Benshaw, Inc

615 Alpha Drive, Pittsburgh, PA 15238, USA

T +1 412 968 0100 **F** +1 412 968 5415

**RIGHT FROM
THE START**

AUCom
MOTOR CONTROL SPECIALISTS